



---

Authorized Distributor





America's most trusted brand

# Parts & Expendables

Unlock Peak Performance



Superior Craftsmanship

Precision.  
Performance.  
Perfection.

## Your Trusted Partner in Precision and Performance

American Mud Pumps Inc. headquartered in Houston, Texas the global hub of the oil and gas industry.

As an agile and forward-thinking company, we specialize in providing high-performance **mud pumps, parts, expendables, and service solutions** for oil and gas operations worldwide.

Built on decades of industry experience, we proudly manufacture American-made mud pumps and offer premium, fully interchangeable parts and expendables compatible with leading American OEM brands.

Our products are trusted in **over 38 countries**, where they power rigs in some of the most challenging environments on the planet.



## Our Promise of Quality and Value

“ We are committed to delivering exceptional products/services, fostering innovation, and creating value for our customers.

Our goals include expanding market share, maintaining sustainable growth, and promoting a positive work culture. By prioritizing customer satisfaction, employee development, and ethical practices,

We aim to be **the most trusted brand** and industry leader worldwide ”



## Global Presence in 38 Countries

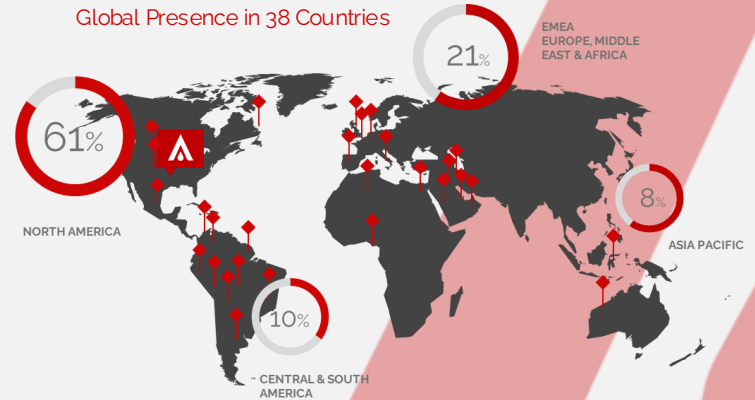

Unlock Peak Performance

# LEADING EFFICIENCY & VALUE

## Superior Craftsmanship

At **American Mud Pumps Inc.**, we don't just manufacture parts, we engineer confidence. With a legacy rooted in excellence and a relentless commitment to quality, we supply the oil and gas industry with high-performance mud pump components that keep rigs running and downtime at bay.

*"When failure is not an option, drillers trust American Mud Pumps to deliver."*

## Precision, Compatibility & Quality

Our brands parts and expendables seamlessly integrate with the most of leading mud pumps in the market, exceeding top industry standards, our robust warranties and exceptional customer support also provide peace of mind to our valued customers.

**AMPX<sup>®</sup>**  
EXPENDABLES

**REDROCK<sup>™</sup>**  
HIGH PERFORMANCE

American Mud Pumps Inc – All Rights Reserved

## Why American Mud Pumps?



### Response Time

Every request is our top priority, expect immediate communication, rapid order processing, and some of the most competitive lead times in the industry.



### Precision & Broad Availability

More parts. More coverage. With over 5,000 part numbers in stock, we offer the largest selection of 100% interchangeable mud pump parts, more than any competitor worldwide.



### American Made Quality

Built tough in the USA using premium materials and precision manufacturing engineered to perform in high-pressure, high-wear environments



### Competitive Pricing

Built to endure, priced to compete. Our components reduce the need for frequent replacements, saving you time and money where it counts.



## CRANKSHAFT ASSEMBLY

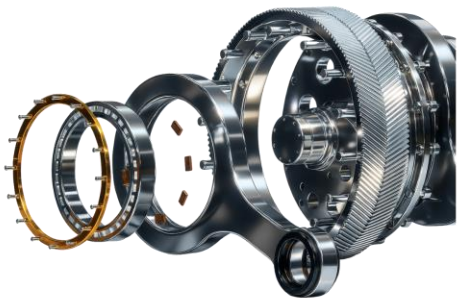

### Crankshaft, Gear, Connecting rods, and bearing systems

Our Crankshaft Assemblies are fabricated to deliver smooth, reliable power transmission in high-demand drilling environments. Each assembly is machined, and balanced to exacting standards, ensuring long-lasting performance and minimal vibration:

**Crankshaft** – Fabricated for strength and fatigue resistance

**Connecting Rod** – High-strength alloy

**Main Gear** – Hardened and aligned for efficient torque transfer

**Cylindrical Roller Bearings** – for high-load capacity, reduced friction

**Eccentric Bearing Outer Race** – Precision-machined for consistent alignment and durability

## MAIN BEARING ASSEMBLY



### Main bearings, bearing housings, bearing outer race. Retainers, and shims.

Our Main Bearing Assemblies are manufactured to support the crankshaft under extreme loads while ensuring smooth, low-friction rotation. Built with precision-machined components and high-load capacity materials, these assemblies are critical to the long-term reliability of your mud pump's power end.

**Main Bearings** – Cylindrical roller or tapered roller types.

**Bearing Housings** – Machined for perfect alignment and secure fit

**Bearing Caps** – Heavy-duty construction for structural integrity

**Shims & Spacers** – For precise preload and alignment

**Seals, Retainers and fasteners**

## POWER PINION SHAFT ASSEMBLY



### Pinion shaft, cylindrical roller bearing, Pinion bearing carrier.

Our Power Pinion Shaft Assemblies delivers efficient torque transfer from the drive motor to the crankshaft, forming a critical link in the mud pump's power end. Built from high-strength alloy steel and precision-machined for perfect gear meshing, these assemblies are fabricated to perform under continuous high-load conditions.

**Pinion Shaft** – Fabricated for strength and fatigue resistance

**Main Gear** – Precision-cut and hardened for smooth torque transfer

**Bearings** – Cylindrical or tapered roller bearings

**Bearing Housings & Retainers** – Machined for vibration control

**Seals, Retainers and fasteners.**

## CROSSHEAD ASSEMBLY

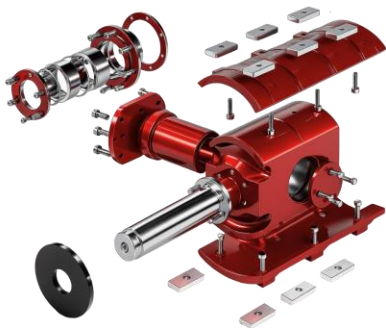

### Crosshead, Wrist pin, stuffing box, baffle disc, crosshead extension and guides

Our Crosshead Assemblies are engineered to ensure smooth, accurate linear motion between the power end and fluid end of your mud pump. Designed for high-load, high-cycle environments, each assembly is built with precision-machined components and wear-resistant materials to maximize performance and minimize downtime.

**Crosshead** – Machined from high-strength alloy.

**Wrist Pin** – Hardened and ground for smooth pivot and load transfer

**Stuffing Box** – Seals from fluid intrusion, ensuring clean operation

**Crosshead Extension** – Connects to the pony rod for axial alignment

**Baffle Disc** – Protects from debris and fluid splash.

## FLUID END ASSEMBLY

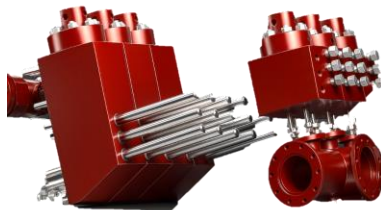

### Our American Mud Pumps fluid end assemblies are designed to withstand high pressures.

Our Fluid End Assemblies are the workhorses of your mud pump system, designed to handle extreme pressures, abrasive fluids, and continuous-duty cycles. Built from premium forged steel and precision-machined to exact tolerances, these assemblies ensure consistent fluid delivery and reduced maintenance in the harshest drilling environments

**Pressure Ratings:** 5,000 , 7,500, 10,000 psi.

**Flow Rates:** 100 to 1,000+ GPM depending on pump size and configuration

- Valve-Over-Valve (VOV) Module
- Valve-Under-Valve (VUV) Module
- Horizontal Valve Module

## PULSATION DAMPENERS



### Pulsation Dampener, Pressure Vessel, Bladder / Diaphragm / Piston, Flanges & Seals

Our Pulsation Dampeners are engineered to reduce pressure fluctuations and vibration in high-pressure mud pump systems. By absorbing pulsations in the discharge line, they protect downstream equipment, improve flow consistency, and extend the life of critical components.

**Pressure Ratings:** 500 psi to 7,500 psi (custom options available up to 10,000+ psi)

**Volume Capacities:** 1 quart to 30 gallons (larger sizes available upon request)



Our AMPX liners: File Hard, High Chrome, and Zirconia Ceramic are engineered for durability, efficiency, and value. Whether you're managing costs, handling abrasive conditions, or operating in high-performance environments, we have the right liner for your rig.



RedRock zirconia liners are built for the most extreme drilling environments delivering unmatched durability under high temperatures and high pressures. With superior resistance to wear, corrosion, and thermal stress, ensuring maximum uptime and efficiency where performance matters most.



**AMPX**  
File Hard Liner



**AMPX**  
High Chrome Liner



**AMPX**  
Ceramic-Zirconia



**REDROCK**  
Ceramic-Zirconia

Feature / Type	AMPX File Hard Liner	AMPX High Chrome Liner	AMPX Ceramic-Zirconia	REDROCK <sup>®</sup> Ceramic-Zirconia
Life expectancy	From 800 to 1,000 hrs	From 1,000 to 1,500 hrs	From 2,000 -to 4,000 hrs.	From 5,000 to 6,000 hrs.
Pressure Rating	Up to 5000 PSI	Up to 7500 PSI	Up to 7500 PSI	Up to 7500 PSI
Temperature Tolerance	Moderate- 230°F	High- Up to 250 °F	Very High - up to 320°F	Excellent- Up to 350°F
Material	Forged steel, carbonized & quenched	High chrome iron alloy	Zirconia ceramic with steel outer shell	Outer: AISI 1045. Inner: ZrO <sub>2</sub> + Y <sub>2</sub> O <sub>3</sub> >99.50.
Hardness (HRC)	Up to 62	60-67	92-94 (Rockwell)	92-94 (Rockwell)
Wear Resistance	Moderate	High	Very High	Extreme
Corrosion Resistance	Low	Moderate to High	Excellent	Excellent
Surface Finish	Standard	Smooth	Ultra-smooth (4-8 RMS)	Ultra-smooth (4-8 RMS)
Sizes Available	4' to 8"	4' to 8"	4' to 8'	4' to 8"
Best Use Case	Budget operations, moderate conditions	High-pressure, abrasive environments	Extreme wear, high-performance drilling	Extreme wear, high-performance drilling

**Disclaimer:** Product performance data is based on controlled testing and typical field conditions. Actual results may vary due to operational factors. No guarantees are implied; users should evaluate suitability for their specific applications.



Our AMPX pistons deliver unmatched durability, sealing, and value no matter the drilling challenge. From extreme HPHT wells to cost-sensitive operations, we have the right piston for your rig.



RedRock pistons are engineered for extreme durability and performance in the toughest drilling conditions. Built with advanced materials, they resist pressure and wear, ensuring long-lasting, efficient operation. Designed to reduce downtime and boost productivity, RedRock delivers the power and reliability your mud pumps need.



Feature / Type	AMPXX <sup>®</sup> Replaceable Rubber	AMPXX <sup>®</sup> Rubber Bonded	AMPXX <sup>®</sup> Urethane Bonded	AMPXX <sup>®</sup> High Temp Urethane Bonded	REDROCK <sup>®</sup> Bull-Nose High Performance
Life Expectancy	100–200 hours (insert only)	100–200 hours	200–350 hours	250–400 hours	300–500 hours
Pressure Rating	Up to 5000 psi	Up to 5000 psi	Up to 7500 psi	Up to 7500 psi	Up to 7500 psi
Temperature Range	Up to 200°F	Up to 200°F	Up to 180°F	Up to 325°F	Up to 350°F
Material	Rubber (replaceable insert)	Nitrile/Synthetic Rubber	Urethane	High-temp Urethane	High Performance/High Temp Urethane
Design	Reusable hub + insert	Bonded	Bonded	Bonded	Bonded, Bull Nose Lip
Mud Compatibility	Water-based muds	Water-based muds	Water & oil-based muds	All mud types	All mud types
Key Advantages	Cost-saving, quick replace	Economical, easy install	Durable, cost-effective	Excellent for heat/pressure	High sealing, long life
Sizes Available	4" to 8"	4" to 8"	4" to 8"	4" to 8"	4" to 8"
Best Use Case	Cost-sensitive operations, training rigs	Shallow wells, water wells	Standard oil & gas drilling	Geothermal, deep wells, HPHT zones	Extreme drilling, high temp/pressure wells

**Disclaimer:** Product performance data is based on controlled testing and typical field conditions. Actual results may vary due to operational factors. No guarantees are implied; users should evaluate suitability for their specific applications.







Our AMPXX 3-Web, 4-Web, and Full Open Valves are engineered for maximum durability, flow efficiency, and reliability in tough drilling conditions. With extended life, high-pressure tolerance, and API-standard compatibility, they're the smart choice for any operation.



RedRock valve assemblies are built for extreme drilling environments, combining advanced materials and precision engineering to deliver unmatched durability and performance. Designed to handle high pressure and abrasive conditions, RedRock keeps mud pumps running reliably with minimal downtime.



Feature / Type	3 Web Valve			4 Web Valve			Full Open Valve		
	AMPXX		REDROCK	AMPXX		REDROCK	AMPXX		REDROCK
	Standard	High Temp	High Performance	Standard	High Temp	High Performance	Standard	High Temp	High Performance
Life Expectancy	400-600 hours	600 - 800 hours	600 - 1,000 hours	400 - 600 hours	600 - 800 hours	700-1,100 hours	300 - 500 hours	500 - 700 hours	600-1,000 hours
Pressure	Up to 7,500 psi			Up to 7,500 psi			Up to 7,500 psi		
Temperature Tolerance	Up to 160°F	Up to 300°F	Up to 350°F	Up to 160°F	Up to 300°F	Up to 350°F	Up to 180°F	Up to 300°F	Up to 350°F
Material	Alloy steel, urethane inserts			Alloy steel, urethane inserts			Alloy steel, urethane inserts		
Design	Three radial webs			Four radial webs			wide open flow path		
Flow Efficiency	Very Good			Very Good			Excellent		
Wear Resistance	High			Very High			Moderate		
Sealing Surface	Double-angle			single-angle			Flat or single-angle		
Sizes Available	4' to 8'			4' to 8'			4' to 8' (standard API sizes)		
Best Use Case	High solids, moderate flow			Harsh, high-pressure, high-solids drilling			High flow, low solids		

**Disclaimer:** Product performance data is based on controlled testing and typical field conditions. Actual results may vary due to operational factors. No guarantees are implied; users should evaluate suitability for their specific applications.





— Let's talk!



---

**Authorized Distributor**

Sarl Nishan Trading  
36, Rue Sidi Yahia Alger (Algérie)  
Phone: +(213) 0770 811 273  
[info@sarlnishan.com](mailto:info@sarlnishan.com)  
[www.sarlnishan.com](http://www.sarlnishan.com)